

OPERATING AND MAINTENANCE  
INSTRUCTIONS

for

TYPE 1001-A

STANDARD-SIGNAL GENERATOR

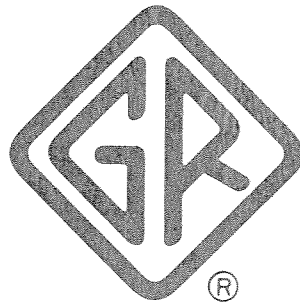

PROPERTY OF  
TES CONSTRUCTION  
DEPT. 614

GENERAL RADIO COMPANY

CAMBRIDGE 39

MASSACHUSETTS

NEW YORK

CHICAGO

LOS ANGELES

U. S. A.

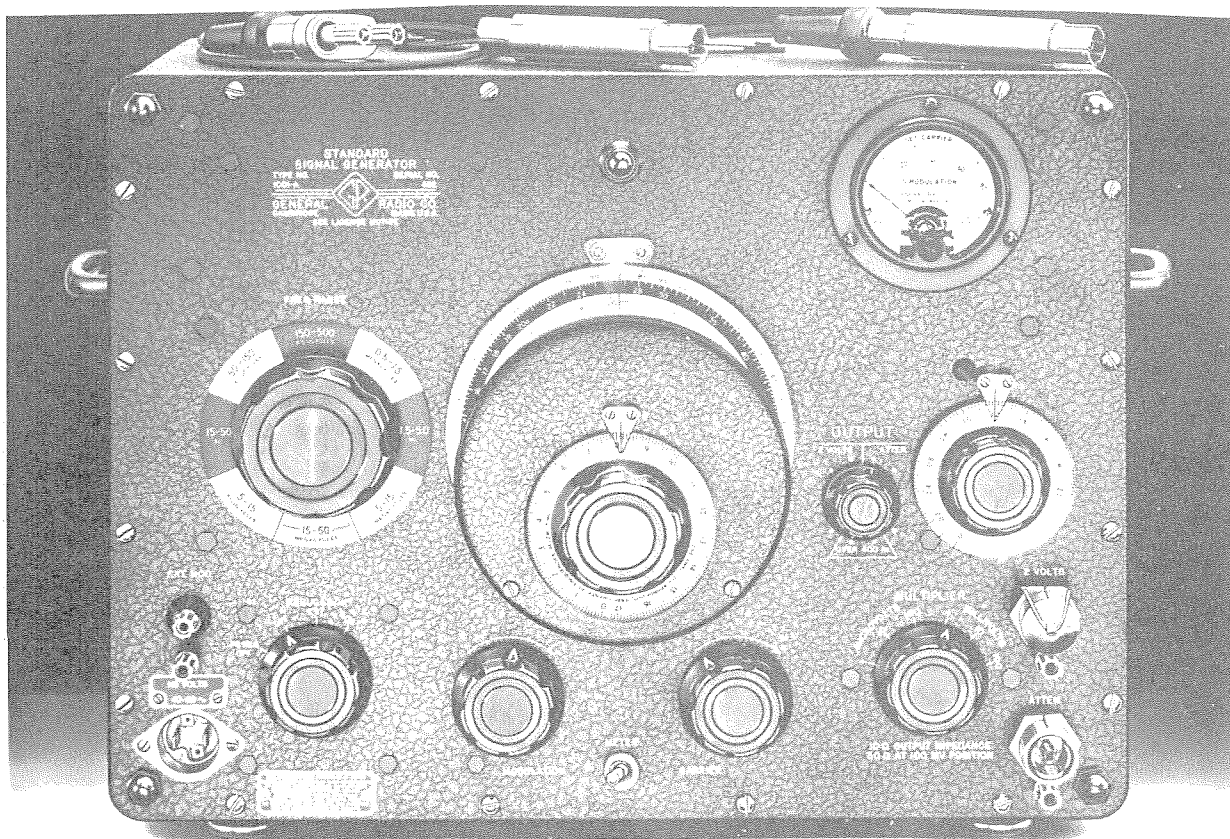

## SPECIFICATIONS

**Carrier-Frequency Range:** 5 kilocycles to 50 megacycles covered in eight direct-reading ranges as follows: 5 to 15 kc, 15 to 50 kc, 50 to 150 kc, 150 to 500 kc, 0.5 to 1.5 Mc, 1.5 to 5 Mc, 5 to 15 Mc, and 15 to 50 Mc.

**Frequency Calibration:** Logarithmic up to 15 Mc, departing slightly from the logarithmic scale at higher frequencies. Accuracy,  $\pm 1\%$ .

**Incremental-Frequency Dial:** Frequency increment is 0.1% per dial division, at frequencies up to 15 Mc.

**Frequency Stability:** Warm-up drift is of the order of 0.25% in 24 hours. Half the maximum drift is reached in 1½ hours; 95% of maximum in four hours. Carrier shift with 80% modulation is 20 parts per million, or less.

**Output Voltage Range:** Open-circuit output voltage at the attenuator jack is continuously adjustable from 0.1 microvolt to 200 millivolts. With output cable terminated at both ends, output voltage is continuously adjustable from 0.05 microvolt to 100 millivolts. Open-circuit output voltage at the 2 volts panel jack is measured directly by the output meter and is 2 volts if the meter is set to the reference mark. This voltage is available up to at least 15 Mc.

**Output Impedance:**\* Output impedance at the attenuator jack is 10 ohms (50 ohms when the series unit is used) except for the highest output position of the attenuator, where it is 50 ohms.

Output impedance at the end of the terminated cable is 25 ohms. Output impedance at the 2 volts panel jack is about 300 ohms.

An output impedance of one ohm (with output voltage reduced 100:1) can be obtained with the TYPE 1000-P3 Voltage Divider, a standard (IRE) test impedance with the TYPE 1000-P4 Dummy Antenna, and a known in-

duction field with the TYPE 1000-P10 Test Loop (see price list below).

**Accuracy of Output Voltages:** At frequencies below 10 Mc, when the output dial is set at about full scale or at about one-tenth full scale, the output voltage is correctly indicated to  $\pm(6\% + 0.1 \mu v)$ . With the output dial set in the mid-scale region, the error may be greater or smaller by 4%. At frequencies above 10 Mc, when the output dial is set at about full scale, the output voltage is correctly indicated to an accuracy of  $\pm(10\% + 0.3 \mu v)$  and the error may be as much as 10% larger or smaller at other output dial settings.

The accuracy of the open-circuit output voltage at the 2 volts panel jack is  $\pm 3\%$  up to 15 megacycles.

**Amplitude Modulation:** Adjustable from zero to 80%. Modulation percentage is indicated on the panel meter and is accurate within  $\pm 10\%$  of the indicated value, with a possible additional error of 2% in modulation level. The internal modulation frequency is 400 cycles  $\pm 5\%$ .

The external modulation characteristic is flat within  $\pm 1$  decibel from 20 cycles to 15 kilocycles. To provide 80% modulation, the external audio oscillator must supply 12 volts into a 4000-ohm load (36 milliwatts).

**Incidental Frequency Modulation:** At 80% amplitude modulation, the incidental frequency modulation varies from about 30 to 300 parts per million over each carrier-frequency range except for the highest frequency range (15 to 50 Mc) where it may be three times as great. At lower modulation percentages, frequency modulation is approximately proportional to modulation percentage.

**Carrier Distortion:** Of the order of 7% on all except the lowest range, where it may increase rapidly, reaching 15%.

**Envelope Distortion:** About 6% at 80% amplitude modulation.

**Noise Level:** Carrier noise level corresponds to about 0.1% modulation.

**Leakage:** Stray fields are substantially less than one microvolt per meter two feet from the generator.

**Terminals:** TYPE 874 Coaxial Terminals are provided for the attenuator output and for the constant 2-volt output.

**Power Supply:** 105 to 125 (or 210 to 250) volts, 40 to 60 cycles. Power input is approximately 65 watts at 115 volts.

**Tubes:** Supplied with the instrument.

1 — 6C4	1 — 5Y3-GT
1 — 6L6	2 — OC3
1 — 6AL5	1 — 6SN7-GT

**Accessories Supplied:** TYPE 874-R21 3-foot Coaxial Cable, TYPE 1000-P1 50-ohm Termination Unit, TYPE 1000-P2 40-ohm Series Unit, TYPE 874-Q2 Adaptor, TYPE TO-44 Adjustment Tool, and a power cord.

**Other Accessories Available:** Not supplied but available on order are the TYPE 1000-P3 Voltage Divider, the TYPE 1000-P4 Standard Dummy Antenna, and the TYPE 1000-P10 Test Loop.

When lower values of incidental fm are required, the TYPE 1000-P6 Crystal Modulator is recommended.

**Mounting:** The instrument is assembled on an aluminum panel finished in black crackle lacquer and mounted in an aluminum cabinet with a black wrinkle finish. The cabinet is provided with carrying handles. A recessed compartment is built into the top of the cabinet for storing the accessories.

**Dimensions:** (Height)  $14\frac{3}{8}$  × (width)  $20\frac{1}{4}$  × (depth)  $10\frac{1}{16}$  inches over-all.

**Net Weight:** 52 pounds.

\*See "Output Systems of Signal Generators," *General Radio Experimenter*, Volume XXI, Number 1, June, 1946.

# OPERATING INSTRUCTIONS

## for

### Type 1001-A Standard-Signal Generator

#### INTRODUCTION

The Type 1001-A Standard-Signal Generator covers the carrier-frequency range from 5 kc to 50 Mc. It may be amplitude-modulated up to 80% over the audio range from 20 c to 15 kc. The carrier output voltage at the attenuator jack is accurately adjustable to any value from 0.1 microvolt to 200 millivolts; output voltages up to two volts are available at a second jack.

Its major application is in the testing of radio receivers. It can also be used as an r-f voltage standard in field-intensity measurements. Its wide carrier-frequency range makes it suitable for use as a power source in bridge measurements and for measurements on supersonic equipment.

#### SECTION 1.0 OPERATION

##### 1.1 POWER SUPPLY

The instrument is supplied complete with tubes and is ready for operation.

The line voltage and frequency are indicated on the nameplate above the power-input receptacle. The power-line-frequency range is 40 to 60 cycles. The voltage range is either 105 to 125 or 210 to 250 volts. If it is desired to change from a 105 - 125 volt condition to a 210 - 250 volt condition, or vice versa, change the power-transformer connections as shown in Figure 1, reverse the nameplate to indicate the appropriate line voltage and replace the fuses as specified in the parts list. The fuses are mounted inside the cabinet.

##### 1.2 FREQUENCY CONTROLS

The two frequency controls are the FREQUENCY RANGE selector switch and the frequency dial. There are eight frequency ranges to cover the spectrum from 4.8 kc to 50 Mc. For rapid identification of the dial scale which corresponds to the selected frequency range, the dial scales and the selector switch segments are alternately etched with light figures on a black background and black figures on a light background except that the 15 - 50 Mc range is identified by a band of two parallel black lines.

For frequencies up to 15 Mc, the percentage frequency change is proportional to angular rotation. The vernier dial has been calibrated to indicate directly small percentage increments in frequency. Each division of this small dial corresponds to a 0.1% change in frequency except at the ends of the main frequency dial.

##### 1.3 METER ZERO

With the power off, the meter should indicate zero. If it does not, it can be adjusted to zero by means of the screw-driver adjustment on the meter.

With the power ON, the CARRIER control in a full counter-clockwise position and the METER switch at CARRIER, the meter should also indicate zero. If it does not after a minute's warm-up period, and if the "mechanical zero" referred to in the preceding paragraph has been correctly set, the "electrical zero" may be set by means of the screw-driver adjustment available through the small panel hole near the OUTPUT dial (below the panel meter).

With the METER switch at MODULATION and the MODULATION control in a full counter-clockwise position, the meter will indicate zero if the "mechanical zero" referred to above has been correctly set.

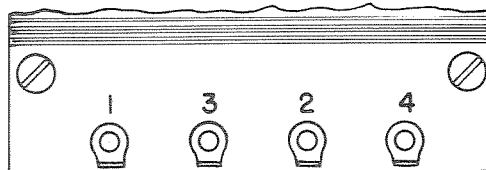

CONNECT #1 TO #3 AND #2 TO #4  
FOR 105 TO 125 VOLT OPERATION

CONNECT #2 TO #3 FOR 210 - 250  
VOLT OPERATION

Figure 1. Power Transformer Connections.

#### 1.4 OUTPUT SWITCH

Output voltage may be obtained either at the 2 VOLTS jack or at the ATTENUATOR jack. The desired jack is selected by the OUTPUT switch. To prevent leakage, the 2 VOLTS jack should be covered with its shielding cap when the output at the ATTENUATOR jack is used.

The OUTPUT switch is also used to control the cut-off frequency of a high-pass filter. When the lower index of the OUTPUT switch is at either of the two "OVER 400 KC" positions, modulation-frequency voltage in the output and at the carrier meter is reduced. At carrier frequencies less than 300 or 400 Kc, the OUTPUT switch must be set to one of the two positions beyond the sector marked "OVER 400 KC" and modulation-frequency voltage in the output can be quite high. See paragraphs 1.62 and 2.4.

#### 1.5 OUTPUT ADJUSTMENT WITH NO MODULATION

To obtain output voltage at the ATTENUATOR jack a fixed carrier level must first be established at the input to the attenuator system by throwing the METER toggle switch to CARRIER and adjusting the CARRIER control until the meter pointer is deflected to the mid-scale point labelled "SET CARRIER". The open-circuit voltage at the ATTENUATOR jack is then continuously adjustable from 0.1 microvolt to 200 millivolts as shown by the reading of the OUTPUT dial (0 - 2.0) multiplied by the setting of the MULTIPLIER switch.

If the 2 VOLTS jack has been selected by setting the OUTPUT switch to either of the 2 VOLTS positions, the open-circuit voltage appearing at this jack is two volts when the meter is at SET CARRIER. This voltage may be varied by re-adjusting the CARRIER control to obtain the multiplying factors indicated (small numerals) either side of SET CARRIER, but this readjustment may cause a slight change in frequency and an increase in distortion as the output is increased.

#### 1.6 OUTPUT ADJUSTMENT WITH MODULATION

**1.61 Modulation Setting:** As determined by the setting of the MODULATION switch, the modulating circuits may be connected for 400-cycle modulation from the internal source, for EXTERNAL modulation (20 to 15,000 cycles) or for no modulation. With the METER switch at MODULATION, the modulation level is indicated on the meter and can be adjusted by means of the MODULATION control to obtain any degree of modulation up to 80%. To provide 80% modulation, the external audio oscillator must be capable of supplying 12 volts into a 4000-ohm load (36 milliwatts).

**1.62 Carrier Setting:** With high percentage modulation, the carrier level is reduced a small amount and must be reset by readjusting the CARRIER control if the modulating frequency is 400 cycles or less. At high

modulating frequencies, the modulating-frequency voltage will affect the carrier meter reading (particularly when the OUTPUT switch is not at the "OVER 400 KC" sector). The carrier level must first be set at a modulating frequency of 400 cycles or lower; the required higher modulating frequency may then be applied. The carrier level will be correct even though the carrier meter will not so indicate.

#### 1.7 OUTPUT IMPEDANCE

The output impedance at the ATTENUATOR jack is 10 ohms for all except the 100 MV MULTIPLIER setting, where the output impedance is 50 ohms.

**CAUTION:** Care must be taken to prevent the introduction of currents from the circuit under test into the attenuator, since excessive currents (greater than 50 milliamperes) may burn out the attenuator resistance cards.

The circuit impedance at the 2 VOLTS jack is approximately 300 ohms. With the OUTPUT switch at 2 VOLTS, the carrier meter is connected directly across the 2 VOLTS output jack and the effective output impedance is zero.

#### 1.8 OUTPUT CONNECTIONS

When shielded connections are not required at low frequencies, open wires may be connected to the binding posts of the Type 874-Q2 Adaptor (supplied with the instrument) which may be plugged into either the ATTENUATOR or the 2 VOLTS jack. Similarly, a Type 274-M Plug (not supplied with the instrument) may be plugged into either output jack and its associated ground terminal.

At higher frequencies a shielded output cable should be used. The Type 874-R20 3-foot Coaxial 50-Ohm Patch Cord is supplied for this purpose and may be plugged directly into either output jack. The Type 874-Q2 Adaptor may then be plugged into the output end of the patch cord to facilitate connections to the instrument under test, or better still, a Type 874 Coaxial Connector (see latest General Radio catalog) may be installed in the instrument under test to maintain coaxial connections throughout.

At frequencies above the broadcast range, proper cable termination becomes important. The 50-ohm patch cord is properly terminated at the generator end for the 100-millivolt position of the MULTIPLIER. At other MULTIPLIER positions, the patch cord is properly terminated if the Type 1000-P2 40-ohm Series Unit (supplied with the instrument) is plugged in between the ATTENUATOR jack and the patch cord. The open-circuit output voltage at the output end of the patch cord is still as indicated by the panel controls but the output impedance is now 50 ohms.

## TYPE 1001-A STANDARD-SIGNAL GENERATOR

Throughout the range, but in particular at the highest frequencies (10 - 50 Mc), the patch cord may advantageously be terminated at its output end by plugging in the Type 1000-P1 50-ohm Termination Unit. This provides a net output impedance which is lower in value (25 ohms) and more constant with frequency. The output

voltage, however, is one-half the voltage indicated by the panel controls.

The Type 874-R21 Patch Cord can be used at the 2 VOLTS jack for frequencies up to 2 Mc but should not be terminated.

### SECTION 2.0 CIRCUIT

#### 2.1 DIAGRAMS

A block diagram is given in Figure 2 and the complete wiring diagram is shown in Figure 3.

#### 2.2 SHIELDING

To reduce leakage and stray fields to a negligible level, the carrier-frequency circuits are contained in a completely closed radio-frequency compartment within the main cabinet. All leads to the radio-frequency compartment are carefully filtered. The two metal shafts that extend from the radio-frequency compartment to the outside of the instrument are well shielded. The cover to the radio-frequency compartment is of double construction with spring contacts bearing on both the inside and outside walls of the compartment.

#### 2.3 CARRIER OSCILLATOR

As shown in the wiring diagram of Figure 3, the Hartley circuit is used in the carrier oscillator. The carrier-frequency range is determined by the setting of a turret which carries the eight range coils and some associated components.

To obtain a compact turret assembly, the coils are mounted alternately on either side of a disc. Each range covers a frequency span of 3.33 to 1 (4.8 to 16 and 15 to 50). The overall range is 4.8 kc to 50 Mc. Since the 100  $\mu\text{mf}$  grid-capacitor (C-4) is too small for the three low-frequency ranges (5 kc - 150 kc), additional capacitance (C-5, C-302) is automatically switched in. The resistor R-2 equalizes the load on the power supply.

The capacitance change of the main tuning capacitor (C-2) is about 750  $\mu\text{mf}$ . The plates are shaped to yield a logarithmic frequency calibration. To increase mechanical stability, the rotor plates are supported at an unusually large inside diameter. The 15 - 50 Mc range does not utilize the entire capacitance span of the main tuning capacitor. The calibration for this range does not follow a logarithmic law and the percentage-frequency-change calibration of the vernier dial does not apply.

The oscillator tube is the Type 6C4 Miniature Triode. The amplitude of oscillation, and hence the final output level, are controlled by adjusting the regulated d-c plate supply of the carrier oscillator by means of R-50, the tapered, 30 kilohm, CARRIER control. The 20 kilohm shunt resistor (R-51) at the CARRIER control equalizes the load on the power supply.

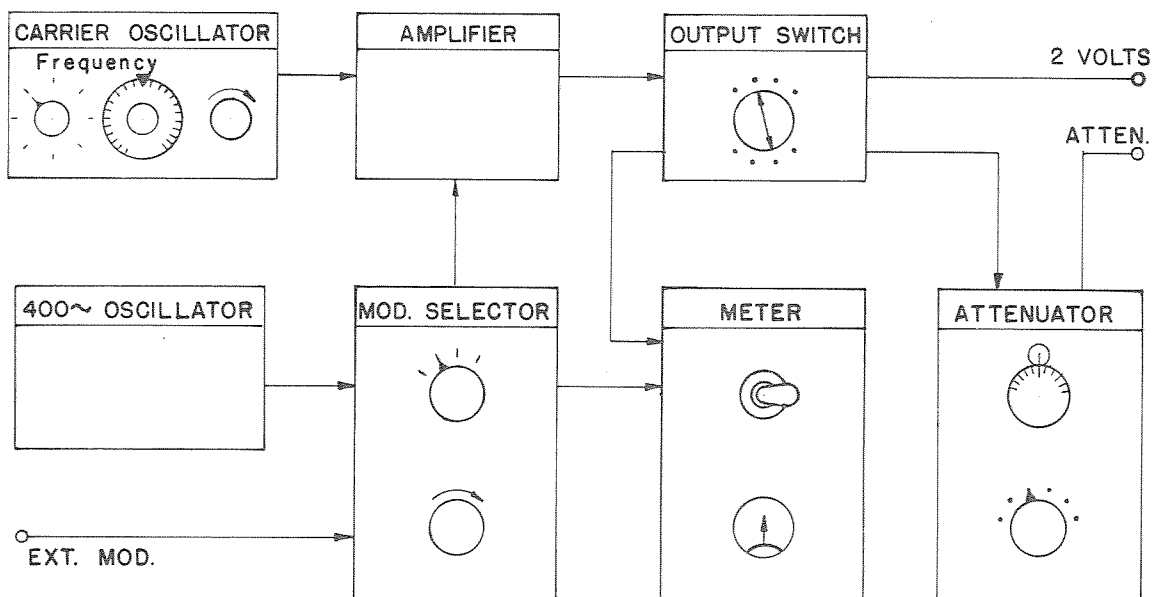

Figure 2. Functional Block Diagram.

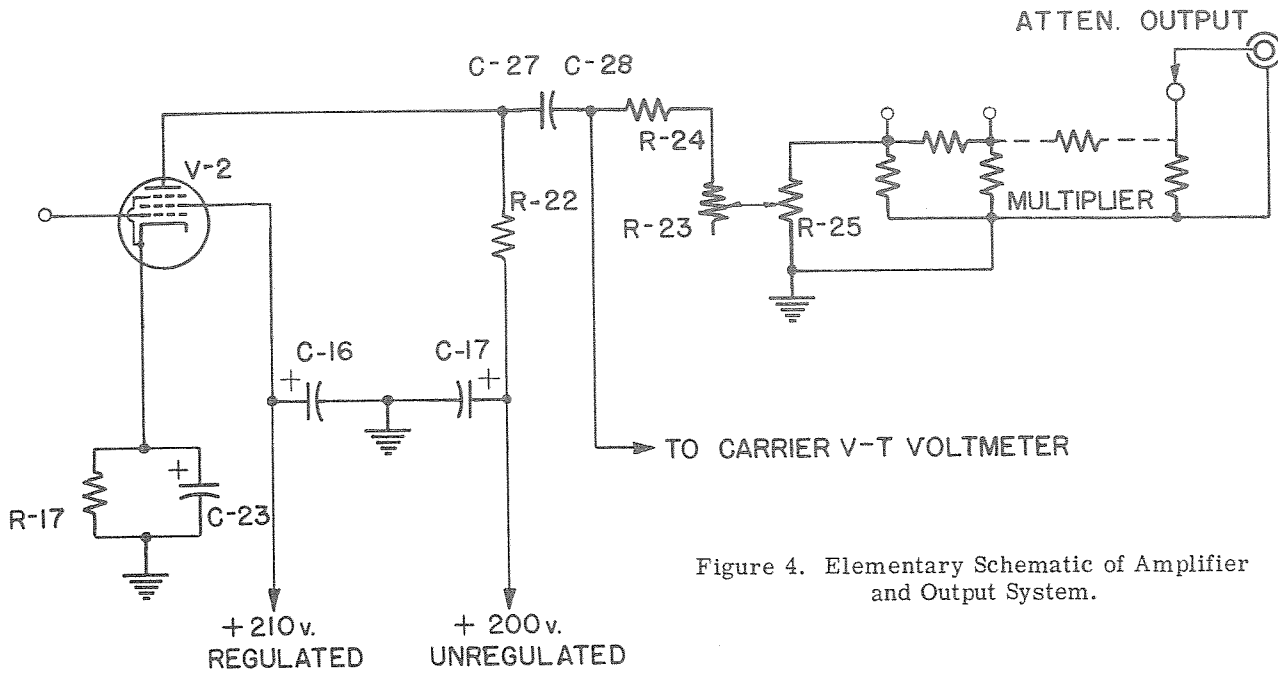

Figure 4. Elementary Schematic of Amplifier and Output System.

The carrier-frequency oscillator is coupled to the amplifier by means of an R-C network to provide the required driving voltage over the entire frequency range. Coupling at high frequencies is adjusted by the small trimmer capacitor C-21.

2.4 CARRIER AMPLIFIER

As shown schematically in Figure 4 and in more detail in the wiring diagram of Figure 3, the 6L6-type beam-power-amplifier tube (V-2) is self-biased and operates as a class A amplifier. The bias due to the voltage drop in R-17 is about -14 volts. The carrier voltage and the modulating voltage are coupled into the grid circuit of the amplifier tube. About 9 volts of audio-frequency voltage are required at the grid of V-2 to obtain 80% modulation. This corresponds to about 12 volts at the EXTERNAL MODULATION terminals. The carrier-frequency voltage required at the grid of V-2 to obtain full

output is about 1.6 volts over most of the mid-carrier-frequency range. The plate circuit therefore contains both carrier- and modulation-frequency voltages. To discriminate against modulation-frequency voltages in the signal-generator output and at the carrier voltmeter, coupling capacitor C-27 (500  $\mu\mu\text{f}$ ) is inserted in the plate circuit. Even so, the unwanted voltage can be half of the carrier-frequency voltage for 80% modulation at the maximum modulating frequency (15 kc). As the modulation level and frequency are reduced, the unwanted voltage is reduced rapidly; at 50% modulation and 400 cycles, it is down to one per cent of the carrier voltage. To pass low carrier frequencies which extend down to 5 kc, C-28, a capacitor of 0.01  $\mu\text{f}$ , is added to C-27, and modulation-frequency voltage in the output circuit is increased by a factor of about twenty.

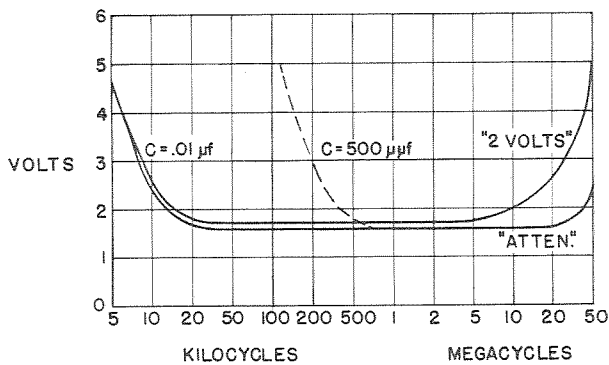

Figure 5. Carrier-Frequency Driving Voltage

The carrier-frequency voltage required at the grid of V-2 depends on the amplifier load and therefore is greater at the extreme ends of the frequency range, particularly at the high end, if the 2 VOLTS position of the OUTPUT switch has been selected. In the ATTENUATOR position, the load is about 330 ohms and consists of R-23 and R-24 in shunt with the carrier-voltmeter diode V-3a. In the 2 VOLTS positions, R-20 is switched in to obtain higher output; this increases the resistive component of the load to about 410 ohms. Since the coaxial cable leading to the 2 VOLTS jack is also switched in, the load is shunted by the comparatively large capacitance of the cable. For this reason, beyond 10 Mc the driving voltage required at the grid of the amplifier tube (V-2) increases with frequency as shown in Figure 5.

2.5 CARRIER VOLTMETER

A fixed-carrier level is established at the input

## TYPE 1001-A STANDARD-SIGNAL GENERATOR

to the attenuator system by setting the CARRIER control (R-50) of the carrier oscillator to obtain a SET CARRIER reading on the panel meter. The carrier-voltmeter diode is connected from the high side of R-24 to ground (Figure 3) and yields a SET CARRIER reading at 1.6 volts. When the resistor R-20 is in circuit (OUTPUT switch at 2 VOLTS) the voltage from the high side of R-20 to ground is 2 volts. The carrier voltmeter is essentially a diode (V-3a) in series with the meter and a calibrating resistor; all components have been selected to give accurate calibration over the entire carrier-frequency range of the instrument. The "dummy" diode, V-3b, balances out the contact potential variations of the active diode. As a result, the zero adjustment and calibration are unaffected by normal line voltage variations. The two sections of the Type 6AL5 Miniature Twin-Diode V-3 serve as the "active" diode V-3a and the dummy diode V-3b of the carrier voltmeter. The electrical zero is adjusted by means of the voltage divider R-12 (a screw-driver adjustment that is available at the panel under the meter) and the sensitivity is adjusted by the rheostat, R-52, which is located inside the instrument.

### 2.6 ATTENUATOR SYSTEM

The attenuator system between the carrier voltmeter and the ATTENUATOR output jack consists of a continuously adjustable L-type network controlled by the OUTPUT dial and a six-position decade ladder network attenuator which serves as a MULTIPLIER.

The L-type network consists of a resistor (R-24), a linear calibrated voltage divider (R-25) and a taper-shaped rheostat (R-23), which maintains the input resistance of the network at 400 ohms as seen from the voltmeter.

Both the rheostat and the voltage divider are Ayrton-Perry wound to reduce the inductance to a minimum. In addition, the voltage divider is mounted on an aluminum block so that it does not act as a one-turn pickup loop when set for zero output.

The L-type network is mounted in the radio-frequency compartment. It is connected to the attenuator (which is mounted on the front panel) through a 274-type plug-and-jack mechanism to permit easy removal of the radio-frequency section from its compartment.

The individual resistors (R-30 through R-39) of the MULTIPLIER attenuator are wound in pairs on small mica cards. Some resistors are wound Ayrton-Perry fashion, and each pair of series and shunt resistors is carefully designed to proportion properly the residual inductances for flat frequency characteristic. The resistance cards are mounted in the segments of a cast housing; the switch contacts are built integrally in the casting for complete shielding between ladder network sections; the switch arm is further shielded from the input to the network by a metal block mounted in the cover of the attenuator housing.

The output impedance as seen at the ATTENUATOR jack is 10 ohms on all but the 100 MV position of the

MULTIPLIER where it is 50 ohms if the calibrated OUTPUT dial of the slide wire (R-25) is set for zero output. At other settings of the OUTPUT dial, the output impedance of the 100 MV position is somewhat less than 50 ohms and reaches a minimum of 43.75 ohms at full-scale setting. This change in output impedance has no effect on the open-circuit output voltage but when using an external termination, it is important to recognize that the impedance varies. Nominally, a 50-ohm termination will halve the output voltage. Actually, when using a 50-ohm termination for the 100 MV position of the MULTIPLIER only, the output voltage may be a maximum of 6-1/2% high unless the following procedure is followed: adjust for SET CARRIER with the MULTIPLIER at any but the 100 MV setting; reset to the 100 MV position; it will be noted that the meter reading will be reduced at the high settings of the OUTPUT dial; if the CARRIER control is not readjusted, the output voltage will be correct.

### 2.7 MODULATION SYSTEM

The modulation system is shown in Figure 3. The modulating voltage may be obtained from the internal 400-cycle oscillator or from an external generator. The amount of modulation is controlled at the panel by the MODULATION voltage-divider (R-56) and is measured by a crystal-type voltmeter. The modulating voltage is then coupled to the grid of the modulating amplifier through a low-pass filter (see Figure 3).

The internal 400-cycle oscillator is of the R-C type where degeneration from plate to grid through a parallel-T network attenuates all but the desired frequency. The oscillator output is coupled to the grid of a cathode-follower stage and thence to the MODULATION selector switch (S-6). The two sections of a type 6SN7-GT twin-triode tube (V-7) serve as audio-oscillator and as amplifier.

The EXTERNAL MODULATION terminals are connected to the MODULATION selector switch through a low-pass filter which prevents carrier-frequency voltages from appearing at the terminals. With the MODULATION switch at EXTERNAL modulation (the worst condition) and the MODULATION control on full, the amount of carrier-frequency voltage at the EXTERNAL MODULATION terminals is about 10  $\mu$ v at 150 kc and decreases very rapidly with frequency to less than 0.1  $\mu$ v at frequencies above 250 kc. This rapid attenuation with frequency is due not only to the low-pass filter at the EXTERNAL MODULATION terminals but also to the R-C-L filters between the MODULATION control and the grid of the amplifier tube V-2.

The output from the MODULATION control is measured by a full-wave rectifier system using two 1N34 germanium crystals, D-1 and D-2, and is indicated on the panel meter (M-1). The rheostat R-53 across the meter provides a means for adjusting the calibration, which extends from zero to 80% amplitude modulation.

The R-C filters at the meter terminals and a shield around the meter prevent carrier-frequency leakage.

## GENERAL RADIO COMPANY

The audio voltage appearing at the grid of the 6L6-type modulator tube (V-2) inside the r-f compartment must be exactly proportional to the audio voltage measured by the crystal-type modulation voltmeter which is mounted outside the r-f compartment. The two points are coupled through an R-C and an L-C filtering network which has a flat frequency characteristic over the audio range up to 15 kc and discriminates sharply against higher frequencies.

### 2.8 ACCESSORIES

All accessories use the universal Type 874 Coaxial Connectors which eliminate the mechanical matching difficulties inherent in conventional plug-and-jack designs.

The Type 874-R21 Patch Cord is a double-shielded 3-foot 50-Ohm coaxial cable of approximately 29  $\mu\mu\text{f}$  per

foot capacitance.

The Type 1000-P1 Termination Unit contains a 50-ohm resistor connected in shunt from the central conductor to the coaxial outer conductor. This unit is intended for proper termination of the Type 874-R21 Patch Cord at the output end.

The Type 1000-P2 Series Unit contains a 40-ohm resistor connected in series with the central conductor. This unit is used to increase the 10-ohm output impedance of the ATTENUATOR jack at all but the 100 MV position to 50-ohm output impedance for proper matching to the Type 874-R21 Patch Cord at the signal generator end.

The Type 874-Q2 Adaptor is used to connect leads to the two output jacks of the signal generator or to the output end of the Type 874-R21 Patch Cord.

## SECTION 3.0 ACCESSORIES FOR RECEIVER TESTING

### 3.1 METHODS

Several methods for testing broadcast receivers have been recommended by the Institute of Radio Engineers (One East 79th Street, New York 21, New York) in the 1948 version of the Standards on Radio Receivers, Methods of Testing Amplitude-Modulation Broadcast Receivers. The test procedures include the use of a standard dummy antenna for testing receivers designed for a conventional overhead-type of antenna and a test loop for testing receivers designed for use with a loop antenna.

### 3.2 STANDARD DUMMY ANTENNA

When the receiver tests require the use of a standard dummy antenna, the Type 1000-P4 Standard Dummy Antenna (not supplied as standard equipment with the instrument) should be connected directly to the receiver antenna terminals (by means of the Type 874-Q2 Adaptor, if need be). The Type 1000-P4 Standard Dummy Antenna is built into a small cylindrical shield and gives the impedance-frequency characteristic shown in Figure 6 with the component values selected as shown in Figure 7 when working out of a 25-ohm source impedance. The Type 1001-A Standard-Signal Generator provides the correct source impedance (25 ohms) when the patch cord is terminated with the Type 1000-P1 50-Ohm Termination Unit. For all but the 100 MILLIVOLT positions, the Type

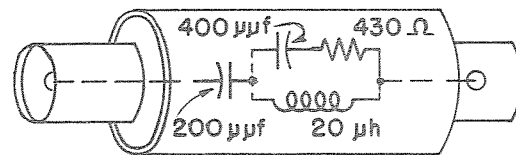
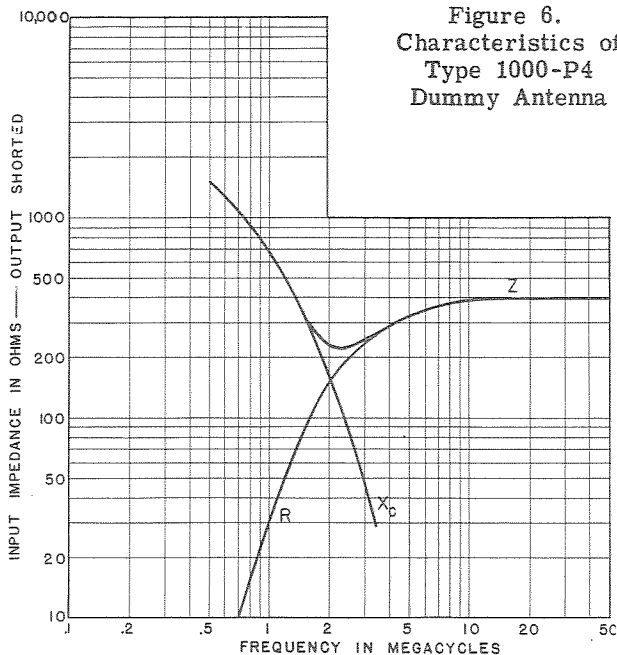

TYPE 1000-P4 STANDARD  
DUMMY ANTENNA

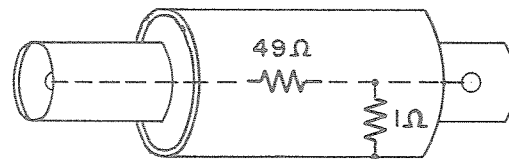

TYPE 1000-P3 VOLTAGE DIVIDER

Figure 7.



## TYPE 1001-A STANDARD-SIGNAL GENERATOR

1000-P2 40-Ohm Series Unit must be connected between the generator and the patch cord. Since the cable is terminated, the output voltage is one-half the voltage indicated by the panel settings.

At the highest frequencies (15 - 50 Mc), if coaxial connections cannot be maintained up to the receiver input terminals, errors in sensitivity measurements can result due to the reactance of the connecting leads. A method for introducing a measured amount of power into the receiver input terminals, in spite of appreciable lead reactance, is described in RCA APPLICATION NOTE number AN 132 of May 17, 1948, entitled, "Receiver Sensitivity and Gain Measurements at High Frequencies". In this method, when the receiver tuning capacitor and an externally added series capacitor are both tuned for maximum receiver output, the receiver presents an effective input resistance which matches the dummy antenna resistance, and the input power may then be calculated.

### 3.3 LOOP ANTENNA - LOW IMPEDANCE METHOD

When the receiver under test is equipped with a loop antenna, it may be tested either with a transmitting test loop connected to the standard-signal generator or by introducing the test signal into the receiver loop through a very low impedance generator.

The Type 1000-P3 Voltage Divider (not supplied as standard equipment with the Type 1001-A Generator) was designed to facilitate the injection of a test signal in series with the receiver loop. The voltage divider is shown schematically in Figure 7. Its 50-ohm impedance at one end of the unit effectively terminates the Type 874-R21 50-Ohm Coaxial Patch Cord and its one-ohm impedance at the other end of the unit is sufficiently low for insertion in series with the receiver's loop antenna without disturbing its normal operation. The voltage appearing at the one-ohm, or loop end of the voltage divider is one hundredth of the voltage indicated by the panel control settings (remember to use the Type 1000-P2 40-Ohm Series Unit at all but the 100 MV MULTI-

PLIER settings). CAUTION: This method is not recommended for use with the ac-dc type of receiver where one side of the power line is connected directly to the receiver chassis. There is considerable shock hazard if the signal generator is operated ungrounded; there is also the danger that the attenuator cards may be burned out.

### 3.4 LOOP ANTENNA - TEST LOOP METHOD

The Type 1000-P10 Test Loop (not supplied as standard equipment with the Type 1001-A Generator) provides a convenient means for measuring loop-antenna receivers in accordance with the preferred method outlined in the I.R.E. Standards mentioned above.\*

The Type 1000-P10 Test Loop is an electrostatically shielded, three-turn coil of ten inches diameter. Figure 8 shows a schematic of the loop and its coupling circuit. The three-turn loop is connected to a four-foot coaxial cable by a 390-ohm resistor to assure constant loop current for a given input voltage up to 3 Mc. The 50-ohm cable is effectively terminated by the 50-ohm shunt combination of a 57.3-ohm shunt resistor and the 390-ohm series resistor. The input to the cable utilizes a Type 874-C Cable Connector.

Figure 9 shows the proper arrangement of apparatus for testing a loop-antenna radio-receiver with a standard-signal generator and the Type 1000-P10 Test Loop.

Note that the loops are arranged coaxially. The separation between the loops should be at least twice the greatest dimension of the larger loop.

\*See also "Measurement of Loop-Antenna Receivers", W. O. Swinyard, Proc. I.R.E., p. 382, July 1941.

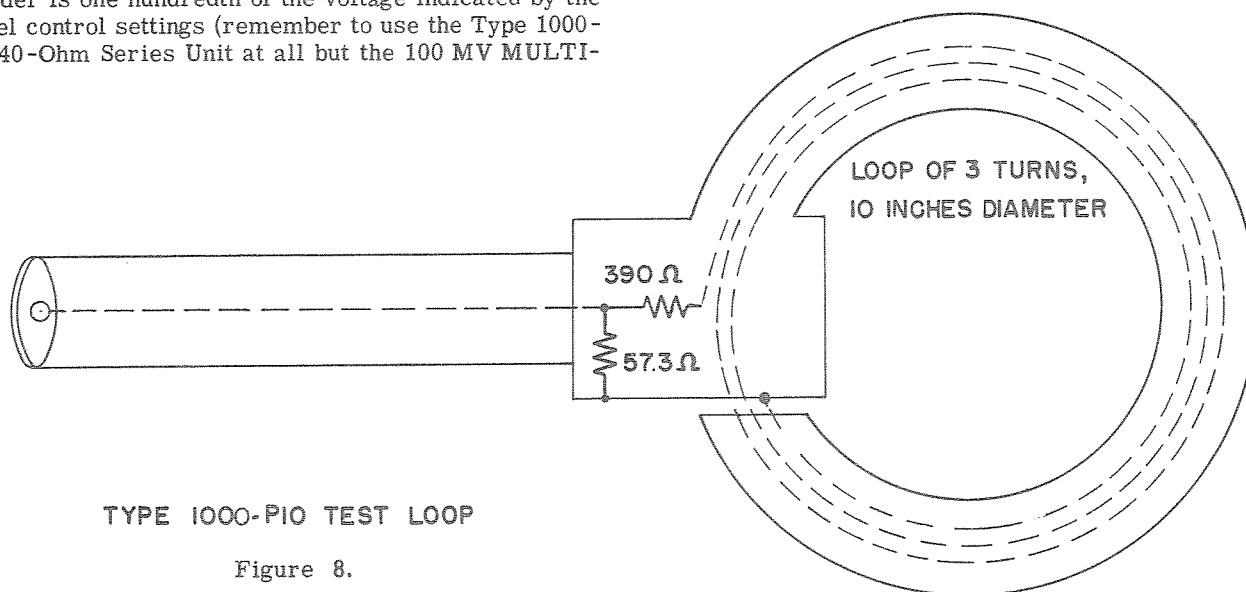

PROJECT: V.  
RES. CONSTRUCTION  
DEPT. #17

GENERAL RADIO COMPANY

The equivalent electric field intensity in microvolts per meter at the center of the receiving loop antenna is:

$$E = \frac{71,250}{(50 + R_0)S^3} E_0$$

Where  $E_0$  is the open-circuit output voltage of the standard-signal generator in microvolts,  $R_0$  (ohms) is the output impedance of the standard-signal generator, and  $S$  (inches) is the separation between the test loop and the receiving loop, as shown in Figure 9.

It is usually convenient to select the separation between loops so that the field intensity is readily expressed in terms of the signal generator voltage,  $E_0$ . For example, when using the Type 1001-A Standard-Signal Generator with its 50-ohm output impedance, the field intensity in microvolts per meter at the receiver loop antenna is one-tenth of the open-circuit output voltage of the generator if the two loops are approximately one-half meter apart. Thus, when the signal generator open-circuit output voltage as indicated on the panel controls is 100 microvolts, the field intensity at the receiver loop is ten microvolts per meter.

Table I lists the loop spacing required under various generator impedance ( $R_0$ ) conditions to obtain a convenient factor for determining the field intensity ( $E$ ) at the receiving loop antenna in terms of the signal generator open-circuit output voltage,  $E_0$ .

The separation "S" between loops is the distance between the outer periphery of the test loop and the center of the receiving loop. The separation "X" between loop centers is somewhat less, as shown in Table I.

TABLE I

$R_0$	$E_0/E$	S (inches)	X (inches)
0 $\Omega$	5	19.3	18.7
	10	24.2	23.7
	20	30.6	30.2
	50	40.9	40.5
	100	52.2	52.0
10 $\Omega$	10	22.8	22.2
	20	28.8	28.4
	50	39.0	38.6
	100	49.2	49.0
37.5 $\Omega$	10	20.1	19.4
	20	25.4	24.8
	50	34.4	34.0
	100	43.3	43.0
	200	54.6	54.3
50 $\Omega$	10	19.3	18.7
	20	24.2	23.7
	50	32.9	32.5
	100	40.9	40.5
	200	52.2	52.0
75 $\Omega$	20	22.5	22.0
	50	30.6	30.2
	100	38.5	38.1
	200	48.5	48.2

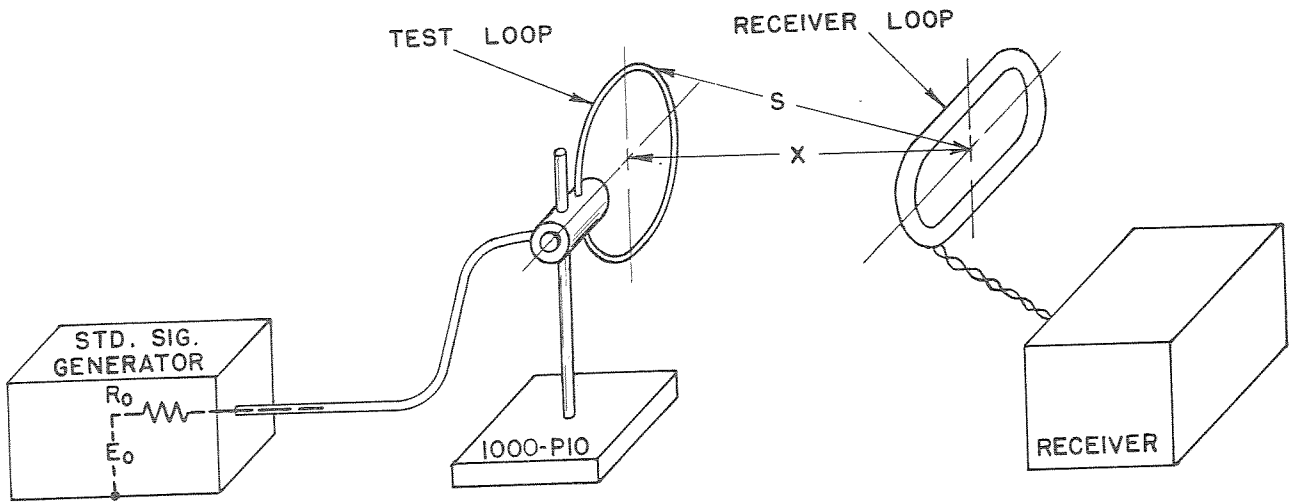

Figure 9.

## TYPE 1001-A STANDARD-SIGNAL GENERATOR

### SECTION 4. ACCESSORY AMPLITUDE MODULATORS

#### 4.1 MODULATION METHODS

The Type 1001-A Generator is normally amplitude-modulated in the grid circuit of its amplifier tube (V-2). There is some incidental frequency modulation (see specifications). While the magnitude of incidental frequency modulation is relatively small, it may be excessive for some applications. Amplitude modulation free of incidental fm can be obtained at carrier frequencies above 10 Mc by using a Type 1000-P6 Crystal Diode Modulator as outlined below.

#### 4.2 TELEVISION MODULATOR

In the Type 1000-P6 Crystal Diode Modulator,<sup>#</sup> the resistance of a 1N21-B type crystal to radio-frequency current is a function of the modulating-frequency voltage across it. As a consequence, the radio frequency output of a Type 1001-A Generator can be amplitude modulated with no incidental fm if the Type 1000-P6 Modulator is connected at the output terminals of the generator. The modulating-frequency characteristic is flat from zero up to several megacycles and it is down only 2 db at 5 megacycles which makes it possible to test at the television intermediate frequency with the Type 1001-A Generator. A convenient source of video modulation voltage is a television receiver tuned to a local station. The Type 1000-P6 Modulator is fitted with Type 874 Coaxial Ter-

minals for the input and output connections and for the modulation circuit. The modulation range is from zero to about 50%; it is not indicated on a meter. The modulator is designed to operate from a 50-ohm source into a 50-ohm load. To avoid distortion, the radio-frequency input to the crystal modulator must be limited to 50 millivolts. The insertion loss is approximately 12 db over the radio-frequency range of 20 - 1000 Mc and it increases to approximately 20 db at 10 Mc.

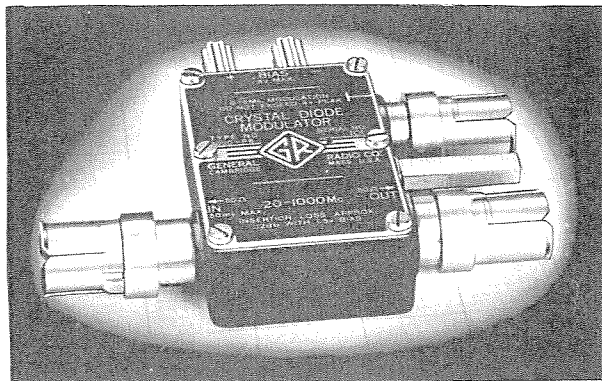

Type 1000-P6 Crystal Diode Modulator

### SECTION 5.0 WIDE-BAND AMPLIFIER TESTS

#### 5.1 EFFECT OF VARYING CARRIER DISTORTION

When a standard-signal generator is used in wide-band amplifier measurements, the usual test procedure is to set the generator voltage at the desired level as indicated by the attenuator settings and by the carrier meter in the generator; the amplifier output is then measured with an external meter. A gain-frequency curve plotted from data obtained from these measurements may exhibit discontinuities at those frequencies where the range switch position of the Type 1001-A Generator is changed. The discontinuities in indicated gain are due to differences in magnitude and character of the carrier distortion and percentage-wise may exceed appreciably the amount of distortion. The carrier meter in the generator is of the low impedance type with a response somewhere between average and positive peak. The response of the external meter may be any one of several types such as positive or negative peak, average, r.m.s., full-wave, half-wave, low or high impedance with consequent varying accentuation of the discontinuities.

<sup>#</sup>W. F. Byers, "A Simple Amplitude Modulator", General Radio Experimenter, March 1950.

Discontinuities and errors in gain measurements are reduced considerably or completely avoided by using the same meter (or two similar meters) to measure both the input and output voltages of the amplifier under test. The output system of the Type 1001-A Generator is well adapted to such a procedure, as outlined below, if complete shielding of the input to the amplifier is not required.

#### 5.2 TEST PROCEDURE

Set the OUTPUT switch of the Type 1001-A Generator to 2 VOLTS. Connect the amplifier under test to the ATTENUATOR jack. Connect a high impedance voltmeter to the 2 VOLTS jack. Use this external meter rather than the internal carrier meter to monitor the input to the attenuator system; disregard the readings of the internal carrier meter. Adjust the CARRIER control to obtain 2 volts on the external meter. Set the OUTPUT dial and MULTIPLIER (attenuator) to the desired amplifier input voltage. Measure the amplifier output voltage with the same external meter or with another meter of similar response characteristics. The amplifier gain is the ratio of the amplifier output voltage to the signal generator output voltage as shown by the output dial and attenuator settings.

## GENERAL RADIO COMPANY

Amplifier gain-frequency curves plotted from data obtained by the above procedure will be free of discontinuities unless the amplifier under test introduces appreciable phase shifts. Since each amplifier stage normally produces a 180 degree phase shift, the external meter connections may have to be transposed at either the 2 VOLTS jack or at the amplifier output terminals

when the amplifier consists of an odd number of stages. With some power-line operated meters, this transposition may introduce serious loading errors which can be avoided by using a battery operated instrument such as the General Radio Company Type 727-A Vacuum-Tube Voltmeter.

### SERVICE AND MAINTENANCE NOTES

#### 1.0 INSTRUMENT IN CABINET

1.1 Power input about 65 watts at 115 volt line.

1.2 CARRIER meter zero may be adjusted by a screw driver through a small panel-hole at top left of OUTPUT dial. See below.

#### 2.0 INSTRUMENT OUT OF CABINET; R-F SECTION COVER REMOVED

2.1 Modulation meter sensitivity adjustment is at rear of audio shelf and is labelled MOD.

2.2 Carrier meter sensitivity adjustment is at rear of audio shelf and is labelled CARRIER.

2.3 The fuses are near the power plug.

2.4 All tubes are accessible.

2.5 The attenuator is accessible. When replacing the attenuator cover, make sure that the block mounted on the cover does not short the MULTIPLIER arm to ground at any MULTIPLIER position.

2.6 Frequency Readjustment: If the oscillator tube (V-1) has been replaced, the frequency calibration at the high-frequency end of each range may need readjustment. A trimmer capacitor for each range is provided for this purpose.

To correct aging effects on the frequency calibration, first, the low-frequency end of each range must be readjusted by means of the dust core and then the high-frequency end of each range must be readjusted by means of the trimmer capacitor.

The dust cores and the trimmer capacitors can be adjusted through holes under a spring strap in the top of the r-f compartment. For the 5 - 15 kc, 50 - 150 kc, 0.5 - 1.5 Mc, and 5 - 15 Mc ranges, the hole through which the dust core can be adjusted is labelled "A" (nearest to panel) and the hole through which the trimmer capacitor can be adjusted is labelled "B". For the 15 - 50 kc, 150 - 500 kc, 1.5 - 5 Mc, and 15 - 50 Mc ranges, the dust core hole is labelled "D" and the trimmer capacitor hole is labelled "C".

The trimmer capacitors are screw-driver adjustments. The dust cores are hex wrench adjustments. A dust core adjustment tool has been provided and is mounted inside the cabinet.

#### 3.0 R-F SECTION REMOVAL

3.1 Before removing the r-f section from its shield compartment, some of the panel knobs and dials must be removed. To maintain the calibration of the OUTPUT dial, reference data must be obtained.

3.11 Set the OUTPUT dial to exactly 1.0 and, with a resistance bridge, measure the d-c resistance from the contact arm of the OUTPUT control (at R-23, available from the rear of the instrument) to ground. The resistance will be approximately 36 ohms. Make a note of the actual value.

3.12 Remove the OUTPUT dial, the FREQUENCY RANGE knob, the main frequency dial and the OUTPUT switch knob.

3.13 Disconnect the cable to the 2 VOLTS jack at the r-f compartment.

3.14 At the rear of the r-f section, remove the four large screws; the r-f section may then be taken out.

3.2 To operate r-f section when removed from its shield compartment:

3.21 Remove the two screws which mount the seven-plug terminal plate (the shaft of the main tuning capacitor goes through this plate). This plug plate and its two-foot cable can be used to connect the r-f section to the corresponding jack plate in the main instrument. The instrument can then be operated to facilitate servicing under operating conditions.

3.22 Before replacing the plug plate, carefully wind the two-foot cable about the supports provided for this purpose.

3.3 To replace the r-f section in its shield compartment, retrace steps 3.14 and 3.13 above.

If any shaft at the panel seems to bind, loosen and

## TYPE 1001-A STANDARD-SIGNAL GENERATOR

then retighten the screws (at the panel) which mount the bearing plates coaxially about the shafts. The bearing plates are behind the panel.

If the plug and jack plates seem to bind, loosen and retighten the two screws that mount the seven-plug plate. These two screws are accessible from the outside of the sub-panel. They are along the center line of the main tuning capacitor near the notches in the front end-plate of the capacitor.

Replace the knobs and dials referred to in Section 3.12 above.

The FREQUENCY RANGE knob is keyed. The insert in the knob serves as a shield over the shaft. It is insulated from the shaft by a thin bakelite sleeve and a small bakelite block. The block fits at the shaft to insulate the shaft from the set screw. Make sure to use the spring washer and metal spacer to ground the knob

insert to the panel. The knob indicates at the ~~5-15 kc~~ <sup>150-500 KC</sup> range when the flat of the shaft is horizontal and flat-side-up.

Orient the main frequency dial to indicate at the reference line for full mesh of the tuning capacitor. Full mesh is obtained by butting the rotor plates against a straight-edge held across the stator plates. The reference line on the main frequency dial is six degrees below the lowest frequency mark. Use the bakelite sleeve to insulate the hub from the main shaft. Use the spring washer to assure good contact between the dial hub and the panel.

The OUTPUT dial must indicate 1.0 when the shaft is set to obtain the resistance from the output control arm to ground, as noted under 3.11 above. The insert in the knob of the output dial must be properly grounded to the panel by means of the metal spacer and the spring washer.

The Type TO-44 Adjustment Tool is mounted in clips on the inside back cover of the instrument.

## PARTS LIST

## Resistors

R-2 = 47	K $\Omega$	$\pm 10\%$	R-41 = 15	$\Omega$	$\pm 10\%$
R-3 = 300	$\Omega$	$\pm 5\%$	R-42 = 6.2	K $\Omega$	$\pm 5\%$
R-4 = 100	K $\Omega$	$\pm 10\%$	R-43 = 560	$\Omega$	$\pm 10\%$
R-6 = 270	$\Omega$	$\pm 10\%$	R-44 = 560	$\Omega$	$\pm 10\%$
R-7 = 270	$\Omega$	$\pm 10\%$	R-45 = 1600	$\Omega$	$\pm 10\%$
R-8 = 270	$\Omega$	$\pm 10\%$	R-46 = 1600	$\Omega$	$\pm 10\%$
R-9 = 560	$\Omega$	$\pm 10\%$	R-47 = 1500	$\Omega$	$\pm 10\%$
R-10 = 33	K $\Omega$	$\pm 10\%$	R-48 = 1000	$\Omega$	$\pm 10\%$
R-11 = 270	$\Omega$	$\pm 10\%$	R-49 = 100	$\Omega$	$\pm 10\%$
R-12 = 1	K $\Omega$		R-50 = 30	K $\Omega$	$\pm 10\%$
R-13 = 10	K $\Omega$	$\pm 2\%$	R-51 = 20	K $\Omega$	$\pm 10\%$
R-14 = 5100	$\Omega$	$\pm 5\%$	R-52 = 5	K $\Omega$	
R-15 = 56	K $\Omega$	$\pm 10\%$	R-53 = 20	K $\Omega$	
R-16 = 750	K $\Omega$	$\pm 5\%$	R-54 = 22	K $\Omega$	$\pm 5\%$
R-17 = 360	$\Omega$	$\pm 5\%$	R-55 = 22	K $\Omega$	$\pm 5\%$
R-19 = 560	K $\Omega$	$\pm 10\%$	R-56 = 20	K $\Omega$	
R-20 = 82	$\Omega$	$\pm 5\%$	R-57 = 10	K $\Omega$	$\pm 10\%$
R-21 = 5.6	K $\Omega$	$\pm 2\%$	R-60 = 2.2	M $\Omega$	$\pm 10\%$
R-22 = 1000	$\Omega$	$\pm 10\%$	R-61 = 27	K $\Omega$	$\pm 10\%$
R-23 = 50	$\Omega$		R-62 = 1	M $\Omega$	$\pm 10\%$
R-24 = 350	$\Omega$	$\pm 1/2\%$	R-63 = 1	K $\Omega$	$\pm 10\%$
R-25 = 95	$\Omega$		R-64 = 680	K $\Omega$	$\pm 10\%$
R-30 = 95	$\Omega$	$\pm 1/2\%$	R-65 = 108	K $\Omega$	$\pm 1\%$
R-31 = 11.68	$\Omega$	$\pm 1/2\%$	R-66 = 515	K $\Omega$	$\pm 1\%$
R-32 = 99	$\Omega$	$\pm 1/2\%$	R-67 = 515	K $\Omega$	$\pm 1\%$
R-33 = 12.22	$\Omega$	$\pm 1/2\%$	R-68 = 100	$\Omega$	$\pm 10\%$
R-34 = 99	$\Omega$	$\pm 1/2\%$	R-69 = 2400	$\Omega$	$\pm 5\%$
R-35 = 12.22	$\Omega$	$\pm 1/2\%$	R-70 = 120	K $\Omega$	$\pm 10\%$
R-36 = 99	$\Omega$	$\pm 1/2\%$	R-101 = 47	K $\Omega$	$\pm 10\%$
R-37 = 12.22	$\Omega$	$\pm 1/2\%$	R-201 = 33	K $\Omega$	$\pm 10\%$
R-38 = 99	$\Omega$	$\pm 1/2\%$	R-301 = 24	K $\Omega$	$\pm 5\%$
R-39 = 11.0	$\Omega$	$\pm 1/2\%$			

## Inductors

L-1 = 250	mh	GR 119-30
L-3 = 60	mh	GR 1001-28
L-101 = 1.335	h	GR 1001-222
L-201 = 137	mh	GR 1001-205-2
L-301 = 13.35	mh	GR 1001-205-3
L-401 = 1.37	mh	GR 1001-205-4
L-501 = 133.5	$\mu$ h	GR 1001-205-5
L-601 = 13.5	$\mu$ h	GR 1001-206
L-701 = 1.3	$\mu$ h	GR 1001-207
L-801 = 0.13	$\mu$ h	GR 1001-208

## Switches

S-1 = 8 Position Freq. Selector	1001-305
S-2 = 4 Position	SWRW-37
S-3 = 6 Position Att. Switch	1001-39
S-4 = D.P.S.T. (mounted on S-6)	
S-5 = D.P.D.T. SWT-335	
S-6 = 4 Position (with S-4)	SWRW-36

## Fuses

F-1 = 0.8 amp. Bussmann 3AG Slo-Blow	For 115 v.
F-2 = 0.8 amp. Bussmann 3AG Slo-Blow	operation
F-1 = 0.4 amp. Bussmann 3AG Slo-Blow	For 230 v.
F-2 = 0.4 amp. Bussmann 3AG Slo-Blow	operation

## Capacitors

C-1		
C-2 = 820	$\mu$ mf	
C-3 = 0.002	$\mu$ f	$\pm 10\%$
C-4 = 100	$\mu$ mf	$\pm 10\%$
C-5 = 0.01	$\mu$ f	$\pm 10\%$
C-6 = 0.5	$\mu$ f	$\pm 20\%$ , $-10\%$
C-7 = 0.5	$\mu$ f	$\pm 20\%$ , $-10\%$
C-8 = 0.5	$\mu$ f	$\pm 20\%$ , $-10\%$
C-9 = 0.5	$\mu$ f	$\pm 20\%$ , $-10\%$
C-10 = 0.5	$\mu$ f	$\pm 20\%$ , $-10\%$
C-11 = 0.5	$\mu$ f	$\pm 20\%$ , $-10\%$
C-12 = 0.5	$\mu$ f	$\pm 20\%$ , $-10\%$
C-14 = 400	$\mu$ mf	
C-15 = 400	$\mu$ mf	
C-16 = 10	$\mu$ f	$\pm 70\%$ , $-10\%$
C-17 = 10	$\mu$ f	$\pm 70\%$ , $-10\%$
C-18 = 5	$\mu$ f	$\pm 70\%$ , $-10\%$
C-20 = 200	$\mu$ mf	$\pm 10\%$
C-21 = 1.5 - 7	$\mu$ mf	
C-22 = 0.047	$\mu$ f	$\pm 10\%$
C-23 = 250	$\mu$ f	$\pm 50\%$ , $-10\%$
C-24 = 500	$\mu$ mf	$\pm 10\%$
C-25 = 0.05	$\mu$ f	$\pm 10\%$
C-27 = 500	$\mu$ mf	$\pm 10\%$
C-28 = 0.01	$\mu$ f	$\pm 10\%$
C-30 = 0.01	$\mu$ f	$\pm 20\%$ , $-10\%$
C-31 = 0.01	$\mu$ f	$\pm 20\%$ , $-10\%$
C-34 = 20	$\mu$ f	$\pm 50\%$ , $-10\%$
C-35 = 20	$\mu$ f	$\pm 50\%$ , $-10\%$
C-36 = 20	$\mu$ f	$\pm 50\%$ , $-10\%$
C-37 = 20	$\mu$ f	$\pm 50\%$ , $-10\%$
C-38 = 20	$\mu$ f	$\pm 50\%$ , $-10\%$
C-39 = 0.5	$\mu$ f	$\pm 10\%$
C-40 = 200	$\mu$ mf	$\pm 10\%$
C-41 = 0.001	$\mu$ f	$\pm 10\%$
C-42 = 0.02	$\mu$ f	$\pm 10\%$
C-43 = 0.001	$\mu$ f	$\pm 1\%$
C-44 = 0.001	$\mu$ f	$\pm 1\%$
C-45 = 0.002	$\mu$ f	$\pm 1\%$
C-46 = 0.02	$\mu$ f	$\pm 10\%$
C-47 = 200	$\mu$ mf	$\pm 10\%$
C-48 = 200	$\mu$ mf	$\pm 10\%$
C-101 = 5 - 20	$\mu$ mf	
C-201 = 5 - 50	$\mu$ mf	
C-301 = 5 - 50	$\mu$ mf	
C-302 = 125	$\mu$ mf	$\pm 10\%$
C-401 = 5 - 50	$\mu$ mf	
C-501 = 5 - 50	$\mu$ mf	
C-601 = 5 - 50	$\mu$ mf	
C-701 = 5 - 50	$\mu$ mf	
C-801 = 3 - 12	$\mu$ mf	

## Miscellaneous

PL-1 = Plug	CDPP-562A
D-1 = Crystal	1N34-A
D-2 = Crystal	1N34-A
T-1 = Transformer	365-459
M-1 = Meter (200 $\mu$ a)	MEDS-31
P-1 = Pilot Light	2LAP-939 Mazda #44

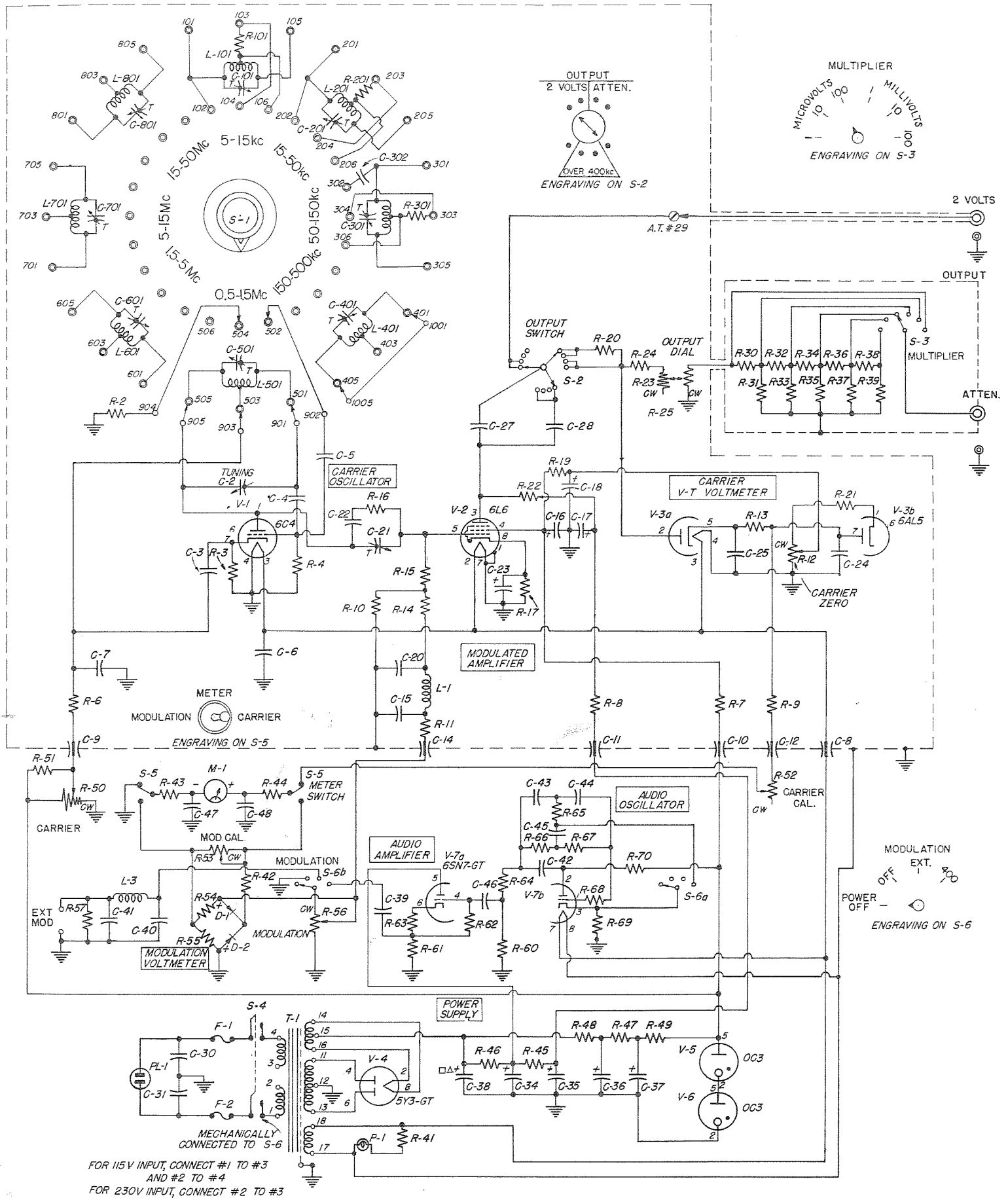

Figure 3. Wiring Diagram for Type 1001-A Standard Signal Generator